

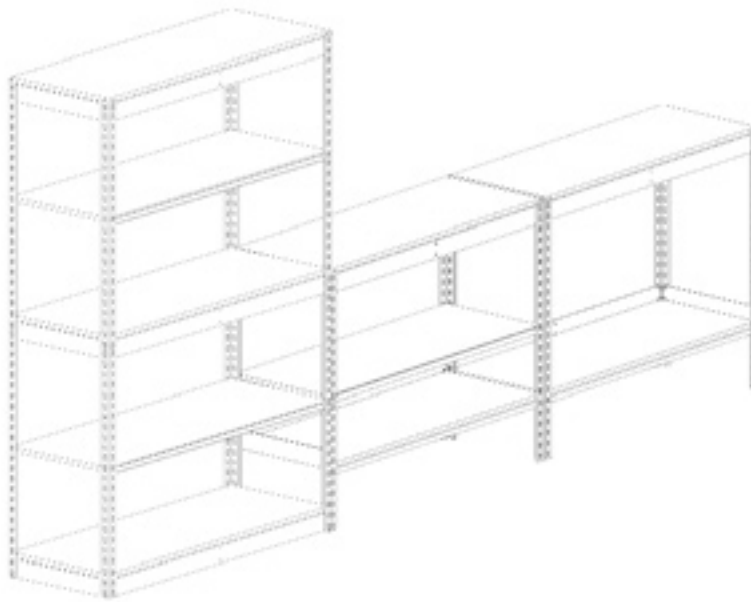

## Assembly Instructions Storage Rack / Workbench



Model: GR 800  
Dimensions (DxWxH):  
Storage Rack - 12" x 30" x 60"  
Workbench - 12" x 60" x 30"

For Instruction Assistance

 **(800) 637-9508**

WEEKDAYS: 8:00 a.m. - 5:00 p.m. Pacific Standard Time

visit us on the web

**[www.theshelvingstore.com](http://www.theshelvingstore.com)**

Gorilla Rack Products is a division of  
Rapid Rack Industries, Inc.  
14421 Bonelli Street  
City of Industry, CA 91746

## Congratulations!

### You have just purchased a superior quality Gorilla Rack Product!

At Gorilla Rack, we pride ourselves in supplying our customers with a superior quality product. If you require any assistance in assembly, or there are any imperfections in our product we need to know. The call you make as a consumer will make a difference in improved services and innovations. All our products have a limited lifetime warranty as shown in the instructions.

Please contact us toll free at:  
800-736-7225 (available for US and Canadian customers only)  
Monday through Friday  
8:00 A.M. to 5:00 P.M. Pacific Time.

To better service you, please have available the Model Number and Lot Tracking Number located on the side of the packaging for your customer service representative.

## Warranty

### LIFETIME LIMITED WARRANTY

This Gorilla Rack® product (exclusive of shelves) is warranted to the original purchaser against defects in material and workmanship. If there are failures of product, Rapid Rack will without charge and upon proof of purchase, repair/replace at our own discretion. Warranty void if product is subject to misuse, abuse, alteration, improper assembly, accident, if used for other than designated purpose or if maximum load capacities are exceeded. This warranty is not transferable and does not cover chipping, flaking, scratches, rust, dents, or other damages to finish or surface of the product. Responsibility of Rapid Rack Industries Inc., is limited to repair or replacement of product. Rapid Rack Industries Inc. is not responsible for consequential, incidental, or other damages or losses resulting from product failure. THIS WARRANTY IS IN LIEU OF ALL OTHER EXPRESS WARRANTIES. SOME STATES DO NOT ALLOW THE EXCLUSION OR LIMITATION OF INCIDENTAL OR CONSEQUENTIAL DAMAGES, SO THE ABOVE LIMITATION MAY NOT APPLY TO YOU. THIS WARRANTY GIVES YOU SPECIFIC LEGAL RIGHTS AND YOU MAY HAVE OTHER RIGHTS THAT VARY FROM STATE TO STATE. In case of product failure, return product to Rapid Rack Industries, Inc., 14421 Bonelli Street, City of Industry, CA 91746.

## Tips

1. Use some type of lubricant to ease the joining of the angle posts and beams.
2. Use a cloth or wood block to protect the surface finish of the product when using a hammer.
3. Rivets must seat at the bottom of the keyhole slot. Hitting the flat section of Double Rivet Beam assists in driving the rivet down the keyhole.
4. Assemble the unit on a sturdy and level surface. Avoid assembly on carpet.
5. Load small stable items on the top shelves, heavier and bulkier item should be stored on the lower shelves.

### ATTENTION

Storage Rack is not recommended for outdoor use. The particle board decks should be sealed with a water proof sealant or paint when used in humid environment to prevent mold.

Optional Beam Assembly

Flange Down will help keep objects from falling over the edge.

Flange Up will help slide object in or out.

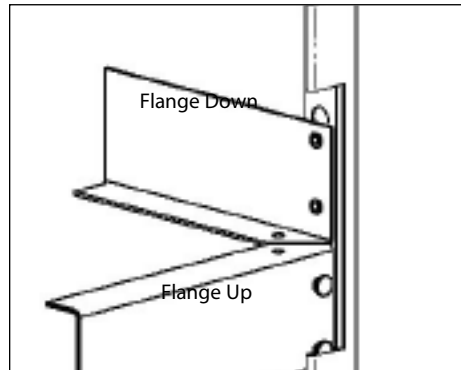

## GR 800 OVERVIEW

## WORKBENCH

To facilitate assembly we recommend having two persons assemble the workbench.

Tool required:  
- Rubber Mallet / Hammer

### Contents GR 800

Item	Description	Qty.
1	Angle Post 30"	8
2	Double Rivet Beam 30"	6
3	Double Rivet Beam 12"	6
4	Single Rivet Beam 30"	4
5	Shelf Deck	5
6	Post Caps	8
7	Tie Pin	4
8	Instructions	1

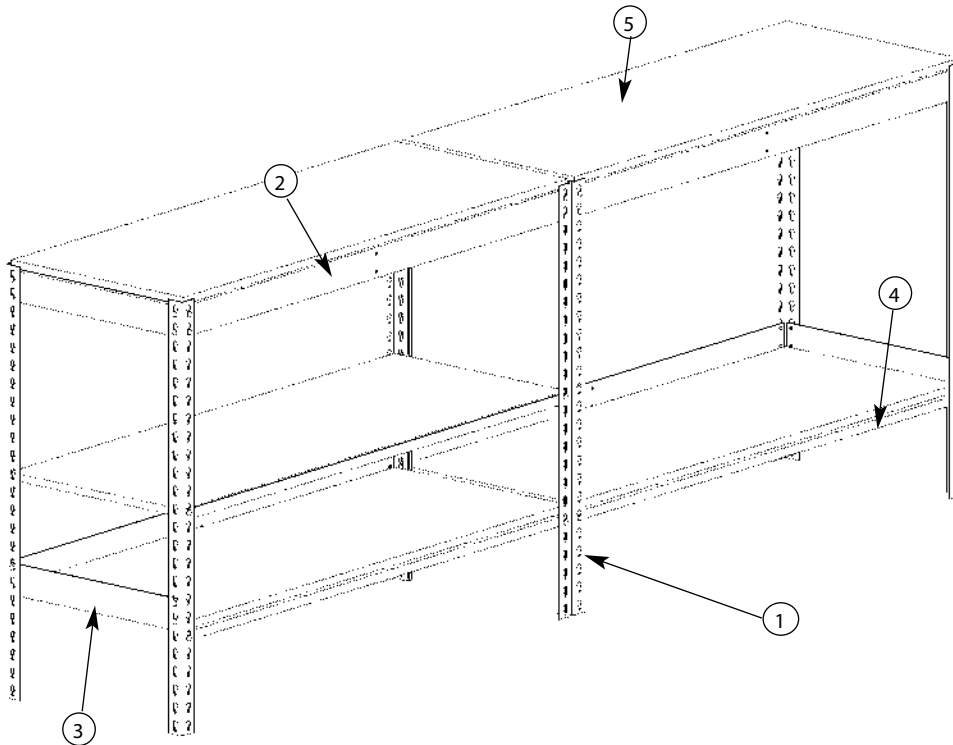
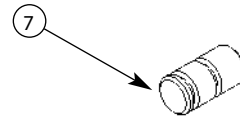
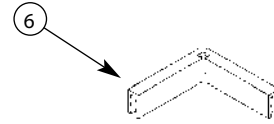

Please read and follow instructions to avoid injuries.

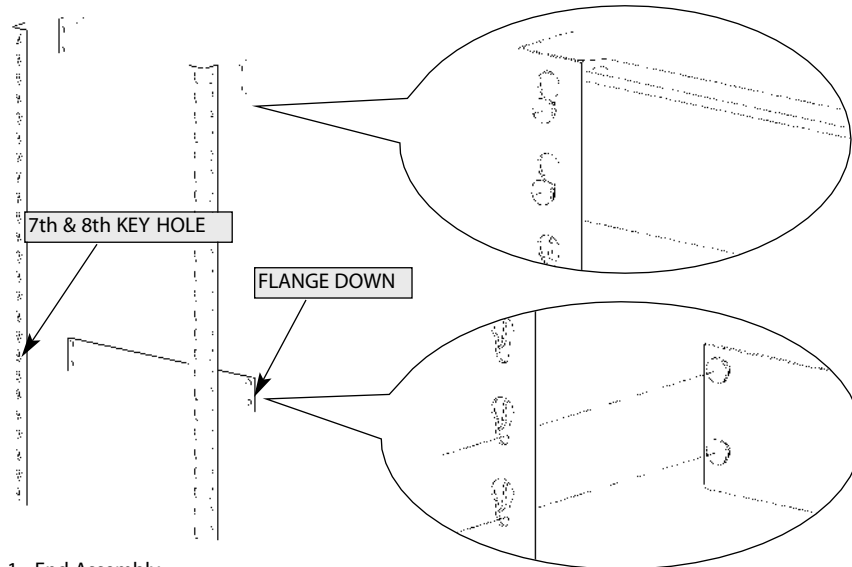

**Step 1 - End Assembly**

Start End Assembly by joining a Small Double Rivet Beam with flange up, to the top keyholes of two Angle Posts. Drive the rivets in by hitting the beam close to post with a rubber mallet locking the joints together. Add an additional Small Double Rivet Beam with flange down into the 7th and 8th key-hole of the two Angle Post. Hit the joints to lock pieces together.

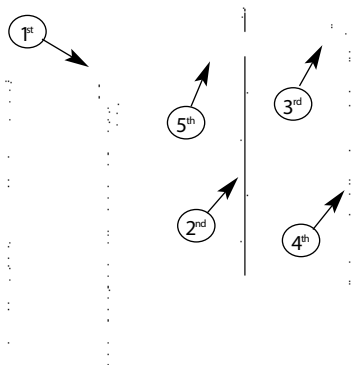

**Step 2 - End Assembly and Long Double Rivet Beams**

Assemble a Long Double Rivet Beam with the flange up to the top two keyholes of the End Assembly and an Angle Post (refer to detail). Hit the joints with a rubber mallet. Assemble a Small Double Rivet Beam to the top two keyholes and add an additional Angle Post and again hit the joints locking the pieces together. Add the second Long Double Rivet Beam to the Angle Post and End Assembly and lock pieces together. Follow the order 1<sup>st</sup> through 5<sup>th</sup> shown in the drawing to facilitate the assembly. Note: Hit the beams near the joints to lock the pieces into place.

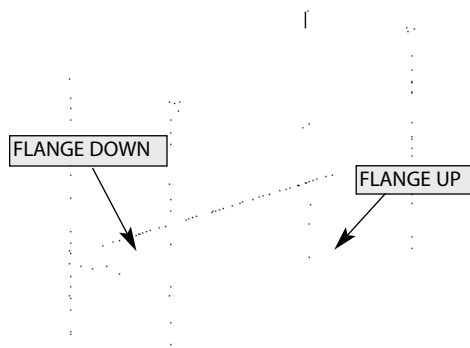

**Step 3 - Bottom Beams**

Assemble a Long Double Rivet with flange down to the rear of the assembly in the 7th and 8th key hole from the bottom of the Angle Posts (refer to detail). Hit the beam near the joints with a rubber mallet to lock pieces together. Add a Single Rivet Beam with the flange up across the front in the 6th keyhole from the bottom (refer to detail). Lock the joints together. Note: the flange may look awkward at this angle and height but it is fully functional.

## GR 800 PRIMARY END ASSEMBLY

## WORKBENCH

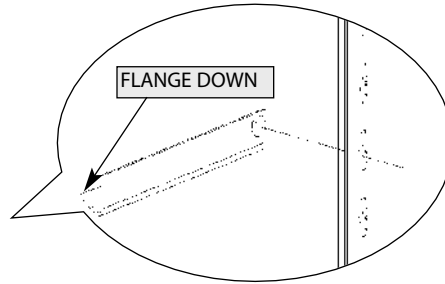
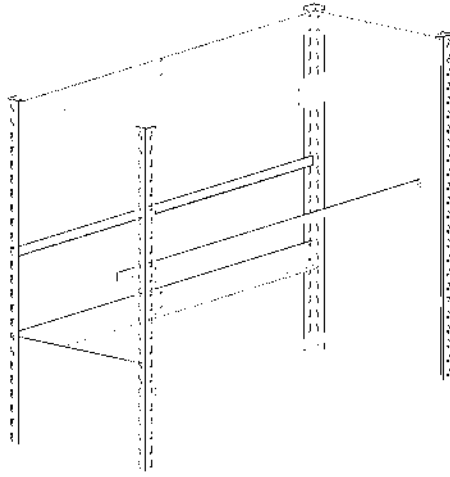

### Step 4 - Single Rivet Beams

Place two Single Rivet Beams across the rear and front of the Angle Posts at the desired height of your shelf. Both beams must have the flange down. Drive the rivets in with a rubber mallet.

## ADD ON UNIT

## WORKBENCH

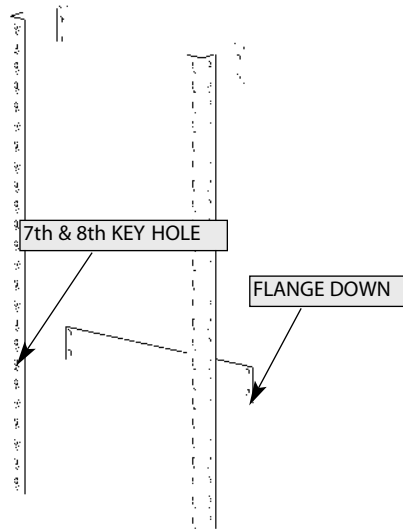

### Step 5 - End Assembly

Start End Assembly by joining a Small Double Rivet Beam with flange up to the top keyholes of two Angle Posts. Drive the rivets in by hitting the beam close to post with a rubber mallet locking the joints together. Add an additional Small Double Rivet Beam with flange down into the 7th and 8th keyhole of two Angle Post. Hit the joints to lock pieces together.

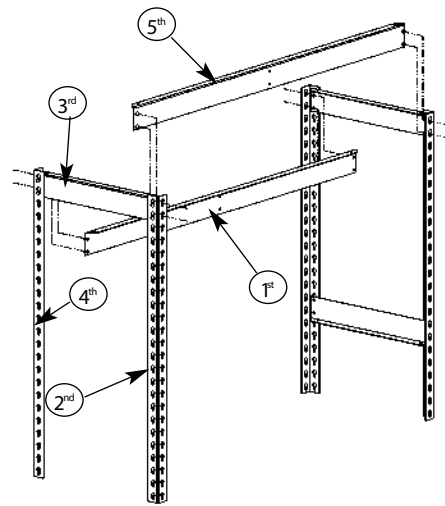

### Step 6 - End Assembly and Long Double Rivet Beams

Assemble a Long Double Rivet Beam with the flange up to the top two keyholes of the End Assembly and an Angle Post (refer to detail). Hit the joints with a rubber mallet. Assemble a Small Double Rivet Beam to side to the top two keyholes and add an additional Angle Post and again hit the joints locking the pieces together. Add the second Long Double Rivet Beam to the Angle Post and End Assembly and lock pieces together. Follow the order 1<sup>st</sup> through 5<sup>th</sup> shown in the drawing to facilitate the assembly. Note: Hit the beams near the joints to lock the pieces into place.

## GR 800 ADD ON UNIT

## WORKBENCH

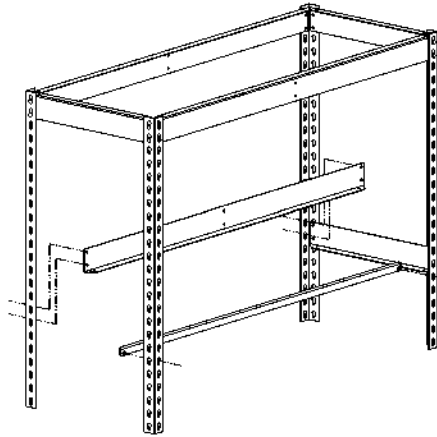

### Step 7 - Bottom Beams

Assemble a Long Double Rivet with flange down to the rear of the assembly in the 7th and 8th key hole from the bottom of the Angle Posts (refer to detail). Hit the beam near the joints with a rubber mallet to lock pieces together. Add a Single Rivet Beam with the flange up across the front in the 6th keyhole from the bottom (refer to detail). Lock the joints together.

Note: the flange may look awkward at this angle and height but it is fully functional.

## COMPLETION

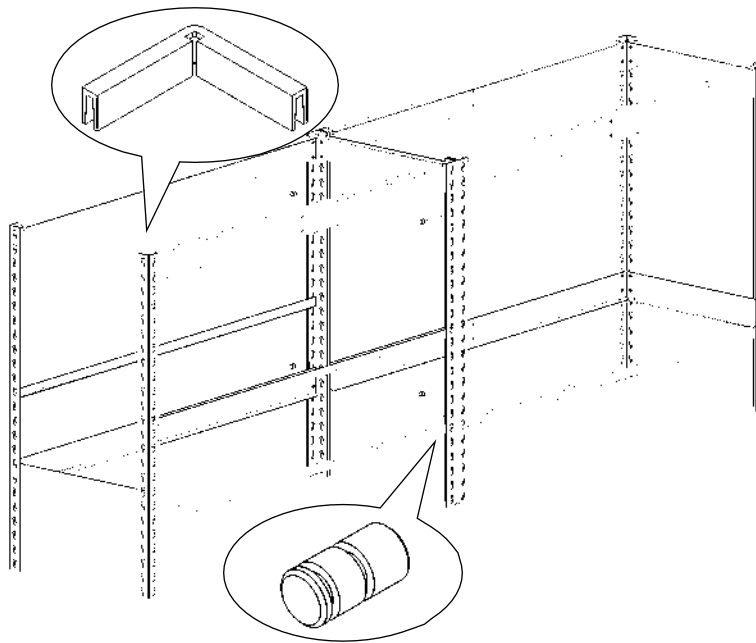

### Step 8 - Tie Pins and Post Caps

Place the two assembled units side by side and insert the tie pins through the keyholes of the two angle post and drive the pins into tapered part of the keyhole with a screw driver and mallet.

Repeat four times (refer to illustration).

### Step 9 - Completion

Lay Shelf Decks into place.  
Add post caps to the top eight exposed Angle Posts.

Congratulations on your completed work bench!

## MODEL GR 800 OVERVIEW

## STORAGE RACK

To facilitate assembly we recommend having two persons assemble the workbench.

Tool required:

- Rubber Mallet / Hammer

Contents GR 800

Item	Description	Qty.
1	Angle Post 30"	8
2	Double Rivet Beam 30"	6
3	Double Rivet Beam 12"	6
4	Single Rivet Beam 30"	4
5	Shelf Deck	5
6	Post Caps	8
7	Tie Pin (required when joining multiple racks together)	4
8	Instructions	1

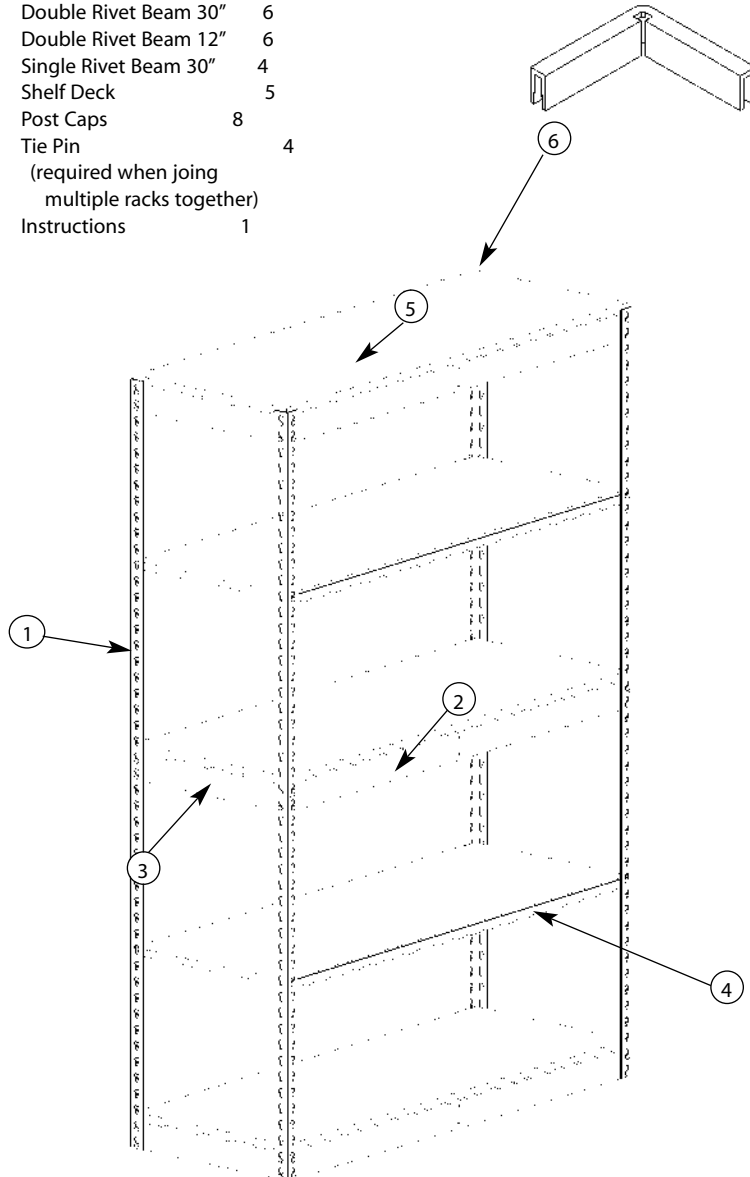

Please read and follow instructions to avoid injuries.

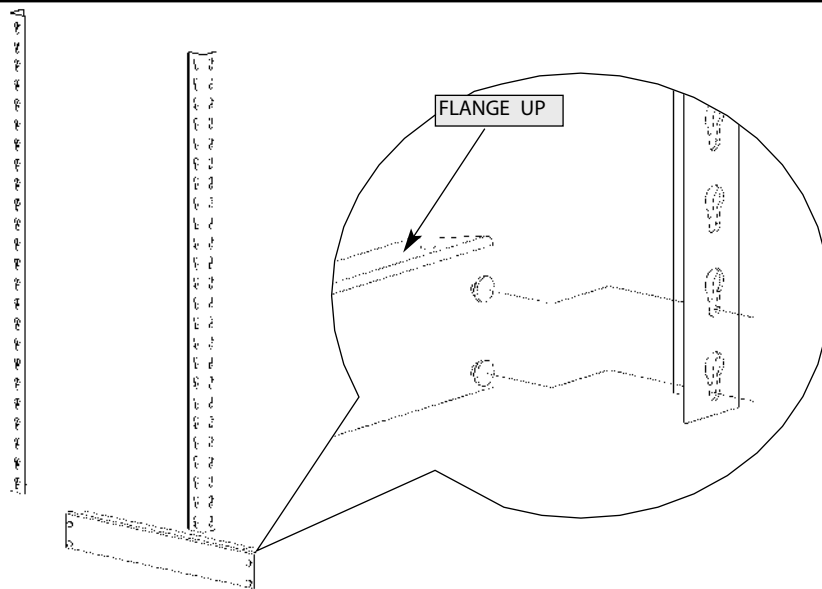

#### Step 1 - Bottom End Assembly

Start bottom of frame assembly by joining a Small Double Rivet Beam with flange up into the two bottom keyholes of an Angle Post. Drive the rivets to the bottom of the key hole by hitting the beam close to post locking the joints together. Repeat to add the second Angle Post creating a Bottom End.

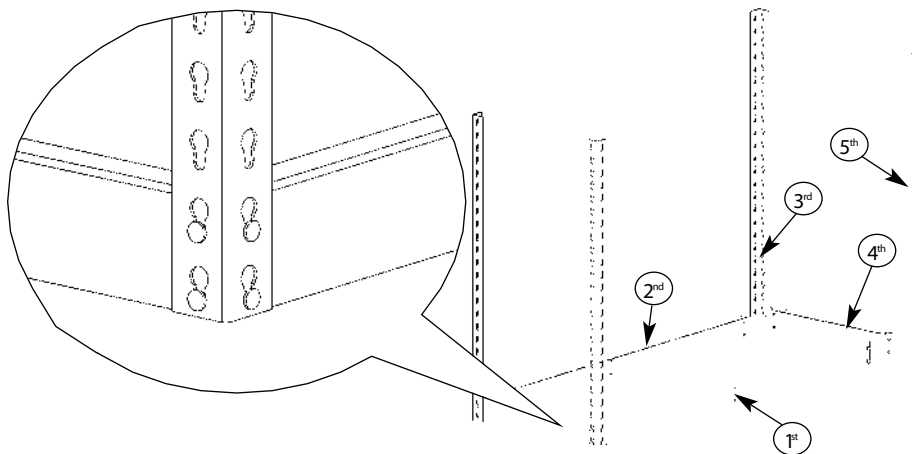

#### Step 2 - Bottom End and Long Double Rivet Beams

Assemble a Long Double Rivet Beam with flange up to the bottom key holes of the Bottom End assembly (refer to detail). Hit the beam with a rubber mallet. Repeat for the opposite Long Double Rivet Beam. Add the Angle Posts and Small Double Rivet Beam to the assembly.

Follow the order 1<sup>st</sup> through 5<sup>th</sup> shown in the drawing to facilitate the assembly.

Note: Hit the beams near the joints to lock the pieces into place.



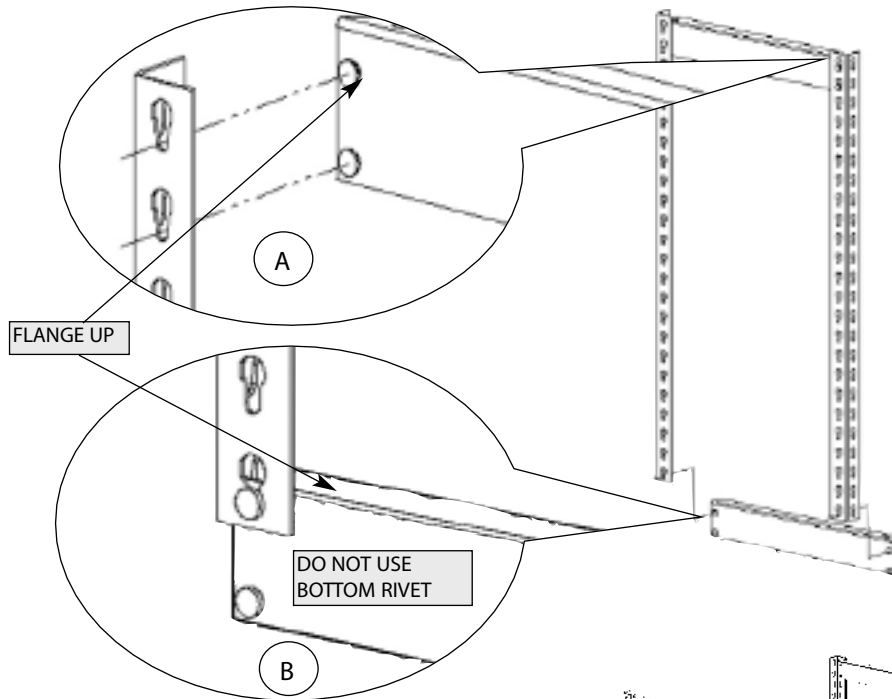

### Step 3 - Top End Assembly

Start the top end assembly by joining a Small Double Rivet Beam into the top keyholes of an Angle Post (detail A). *Be sure the flange faces up.* Add the second Angle Post. Hit the beam close to joints to lock pieces together. Add the Bottom Small Double Rivet Beam (detail B) and lock pieces together. Only use the top rivet, the bottom rivet will be used to join the top end to the bottom assembly. Repeat Step for the opposite top end.

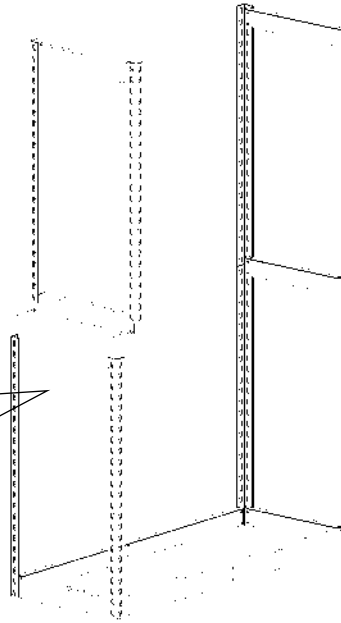
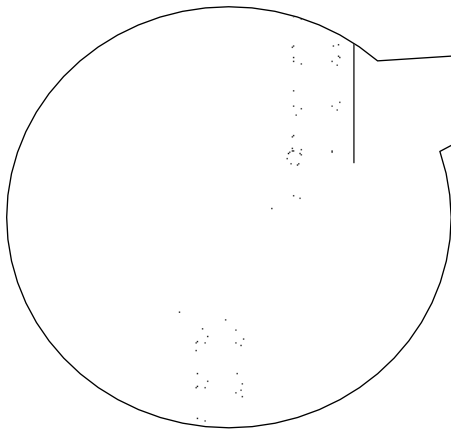

### Step 4 - Joining Assemblies

Join the top end to the bottom assembly angle post. Insert the open rivets to the top keyhole of the angle post, refer to the detail for proper placement. Insert both rivets into the posts before hitting joints. Repeat Step 2 for the opposite end.

Note: Angle posts do not overlap.

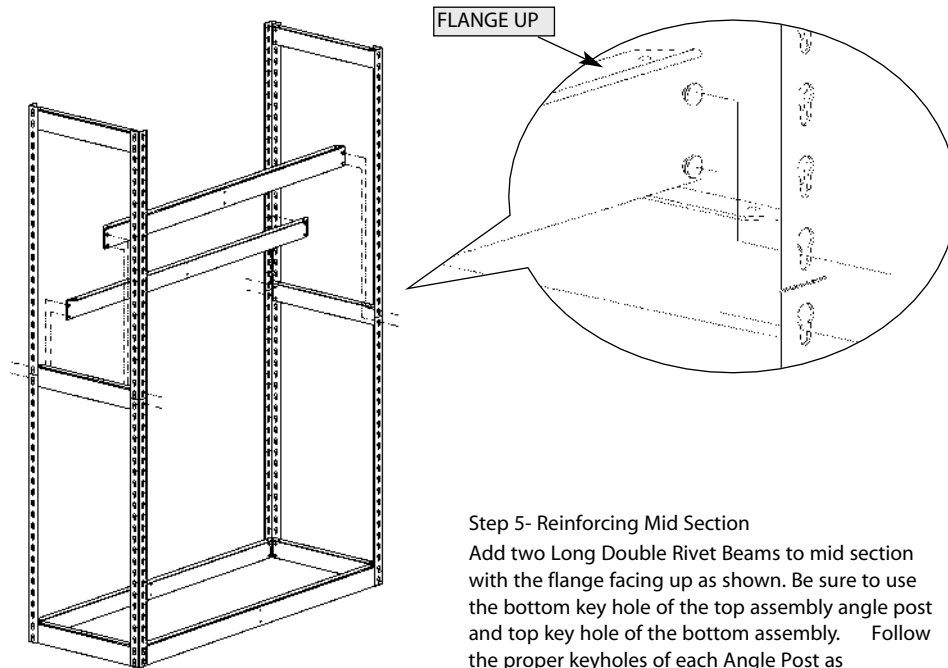

#### Step 5- Reinforcing Mid Section

Add two Long Double Rivet Beams to mid section with the flange facing up as shown. Be sure to use the bottom key hole of the top assembly angle post and top key hole of the bottom assembly. Follow the proper keyholes of each Angle Post as shown in the detail illustration. Be sure to have the rivets in the keyholes before hitting the joints.

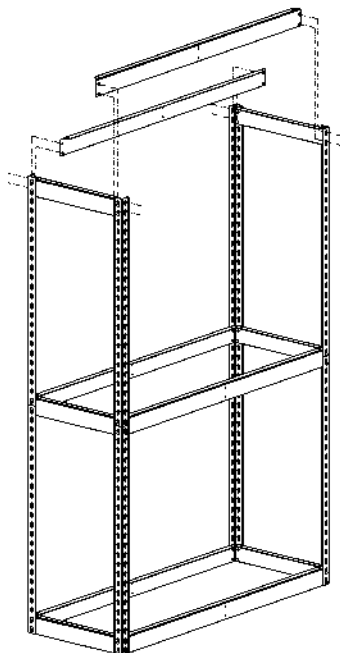

#### Step 6 - Reinforcing Top Section

Add two additional Long Double Rivet Beams to the top two key holes of the angle post as shown. Be sure to have all rivets in the keyholes before hitting the joints

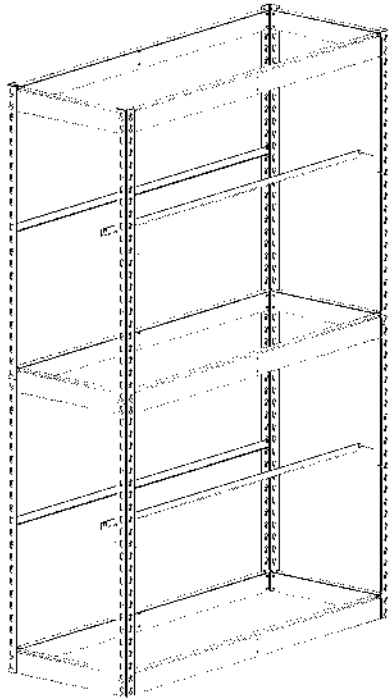

FLANGE DOWN

**Step 7 - Single Rivet Beam Shelves**

Assemble the remaining Single Rivet Beams to your desired location on the angle post. *Be sure to have the flange down*, hit joints to lock pieces together.

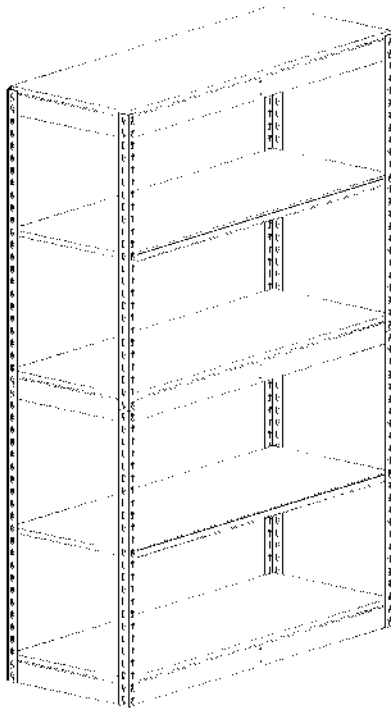
**Step 8 - Shelf Decks and Post Caps**

Lay the Shelf Decks into Place. Add four Post Caps to the top 4 corners as shown in the detail.

Congratulations on your completed storage rack!