

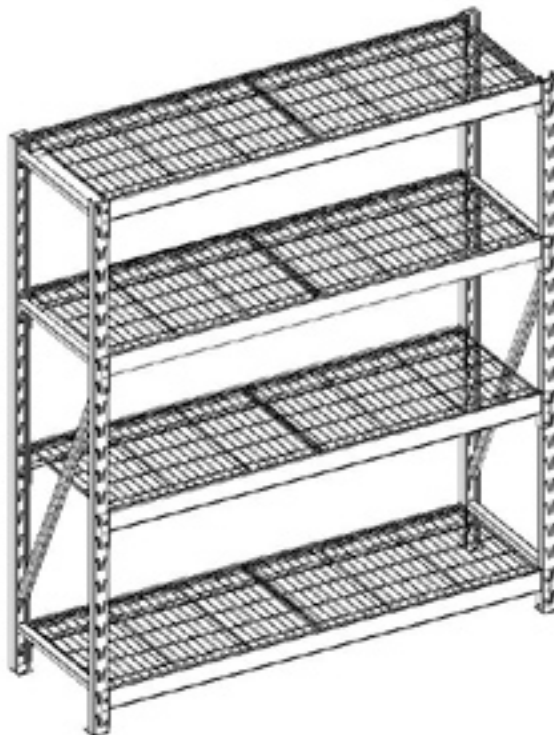

# Assembly Instructions

## Wire Deck Package Rack / Heavy Duty Bulk Storage



Models:  
GR 7304 - 77" x 24" x 72"

*For Instruction Assistance*

 **(800) 637-9508**

*WEEKDAYS: 8:00 a.m. - 5:00 p.m. Pacific Standard Time*

*visit us on the web*

**[www.theshelvingstore.com](http://www.theshelvingstore.com)**

Gorilla Rack Products is a division of  
Rapid Rack Industries, Inc.  
14421 Bonelli Street  
City of Industry, CA 91746

## Congratulations!

You have just purchased a superior quality Product!

We pride ourselves in supplying our customers with a superior quality product. If you require any assistance in assembly, we need to know. The call you make as a consumer will make a difference in improved services and innovations.

Please contact us toll free at:  
800-736-7225 (available for US and Canadian customers only)  
Monday through Friday  
8:00 A.M. to 5:00 P.M. Pacific Time.

To better service you, please have available the Model Number and Lot Tracking Number located on the side of the packaging for your customer service representative.

## Warranty

### CONSUMER PRODUCTS WARRANTY INFORMATION

This Gorilla Rack® product (exclusive of shelves) is warranted to the original purchaser. If there is failure of product due to defects in material and workmanship, Rapid Rack will without charge and upon proof of purchase, repair/ replace at our own discretion. Warranty is void if product is subject to misuse, abuse, alteration, improper assembly, accident, if used for other than designated purpose or if maximum load capacities are exceeded. This warranty is not transferable and does not cover chipping, flaking, scratches, rust, dents, or other damages to finish or surface of the product. Responsibility of Rapid Rack Industries Inc. is limited to repair or replacement of product. Rapid Rack Industries Inc. is not responsible for consequential, incidental, or other damages or losses resulting from product failure.

THIS WARRANTY IS IN LIEU OF ALL OTHER EXPRESS WARRANTIES. SOME STATES DO NOT ALLOW THE EXCLUSION OR LIMITATION OF INCIDENTAL OR CONSEQUENTIAL DAMAGES, SO THE ABOVE LIMITATION MAY NOT APPLY TO YOU. THIS WARRANTY GIVES YOU SPECIFIC LEGAL RIGHTS AND YOU MAY HAVE OTHER RIGHTS WHICH VARY FROM STATE TO STATE. In case of product failure, damaged or defective material, refer to Rapid Rack Industries, Inc. 14421 Bonelli Street, City of Industry, CA 91746 or 1-800-736-7225.

## Tips

1. Group similar size parts together before starting your assembly.
2. Use some type of lubricant to ease the joining of the uprights and load beams.
3. Use a cloth or wood block to protect the surface finish of the product when using a hammer
4. Clips must seat at the bottom of the slot. Hit the flat section of beam.
5. Assemble the unit on a sturdy and level surface. Avoid assembly on carpet.
6. Load small stable items on the top shelf, heavier and bulkier items should be stored on the lower shelf.

**ATTENTION: This unit is not recommended for outdoor use. All particle board decks should be sealed with a water proof sealant or paint when used in humid environment to prevent mold.**

## Parts Overview

## Wire Deck Package Rack

Two people required for assembly

**Tools required:**  
- Rubber Mallet or hammer

### CONTENTS:

Item	Description	Qty.
1	Uprights	2
2	Load Beams	8
3	Wire Deck	8

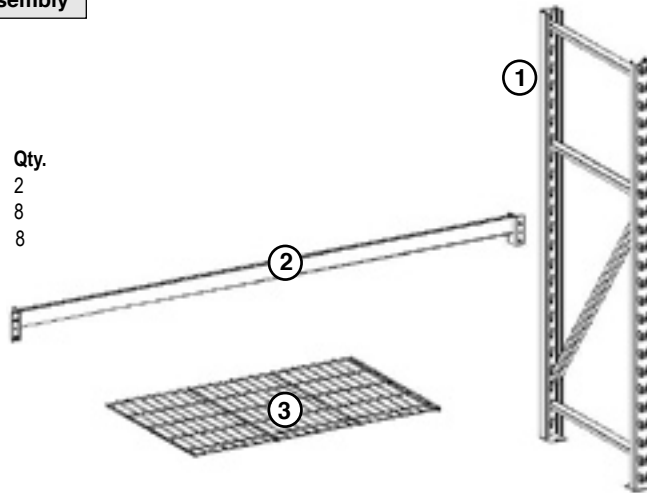

## Step 1:

### BOTTOM ASSEMBLY - BACK LOWER LOAD BEAM

After grouping parts for assembly, verify that all contents have been included. Have one person hold the upright in standing position while the second person inserts a load beam in the lower part of the upright. Begin with lower back load beam.

Insert the beam clips into the upright slots at the bottom (uprights have 3" increments). Hit the load beam near the joint with a rubber mallet to drive the beam clips to the bottom of the slot (see detail).

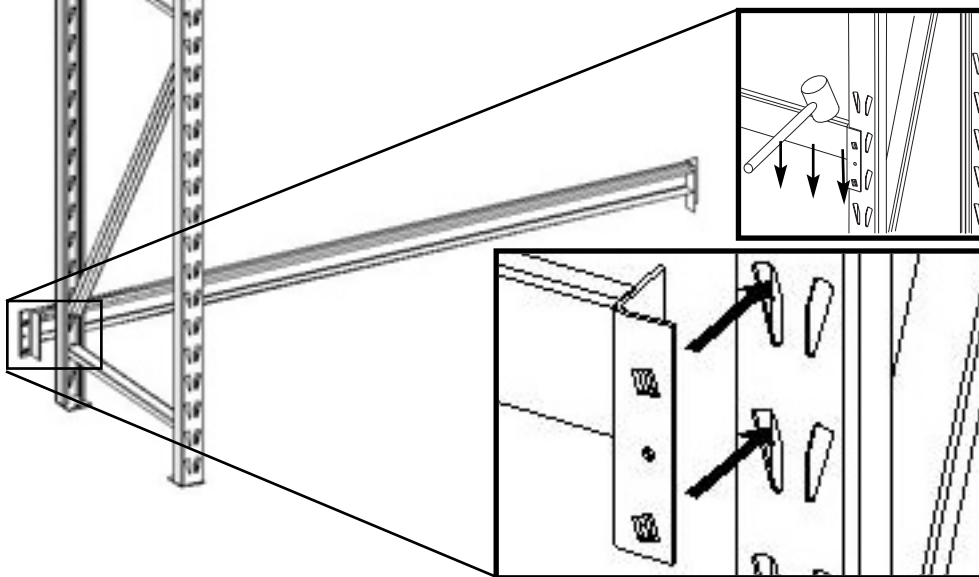

## Step 2:

### BOTTOM ASSEMBLY (CONTINUED)

Join the load beam to the other upright at the same slot level. Count slots to help you align load beams height. Insert the load beam clips into the upright slots. Hit the beam near the joint with a rubber mallet to drive the beam clips to the bottom of the slot (see detail).

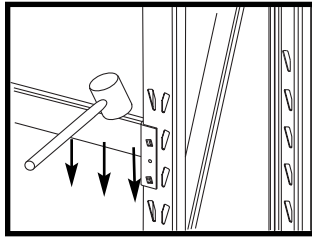

*Be sure the load beam clips in step 1 remain locked.*

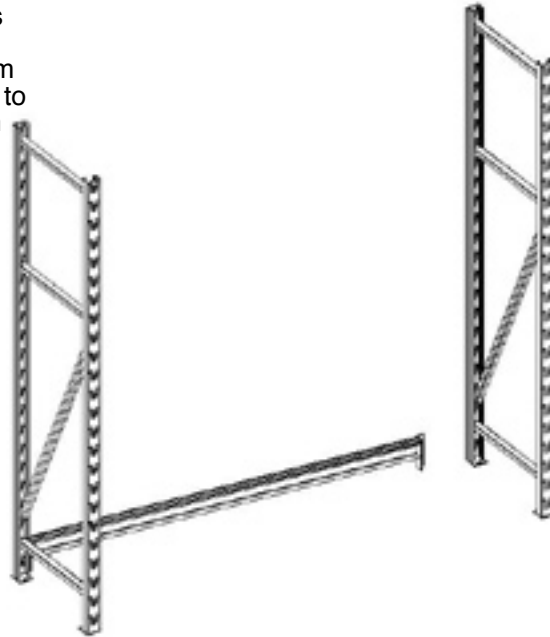

## Step 3:

### FRONT LOWER BEAM

Repeat step 1 & 2 to install front lower load beam - be sure it is at the same level as the back load beam.

Count slots to help you align the load beams height.

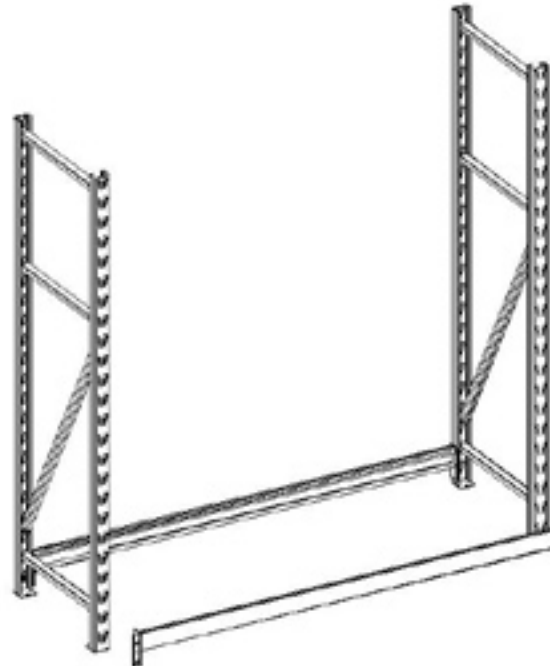

## Step 4:

### TOP AND MID SECTION LOAD BEAMS

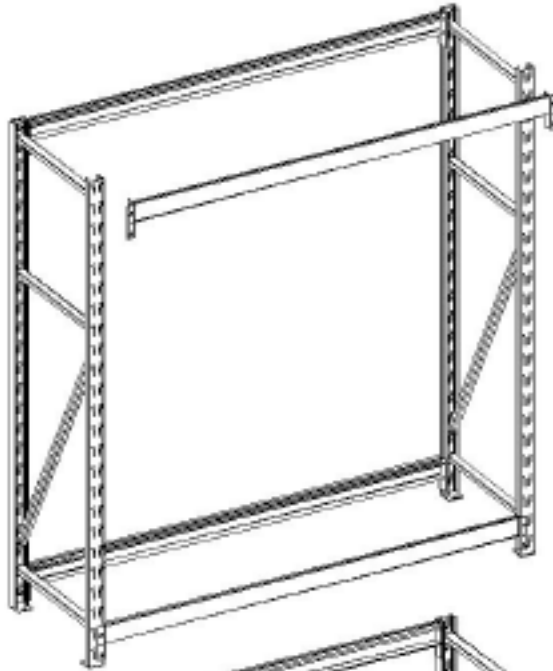

First install the back top load beam. Insert the load beam clips into the two top slots of each uprights. Hit the beam near the joint with a rubber mallet to drive the beam clips to the bottom of the slot.

Repeat step for front top load beam.

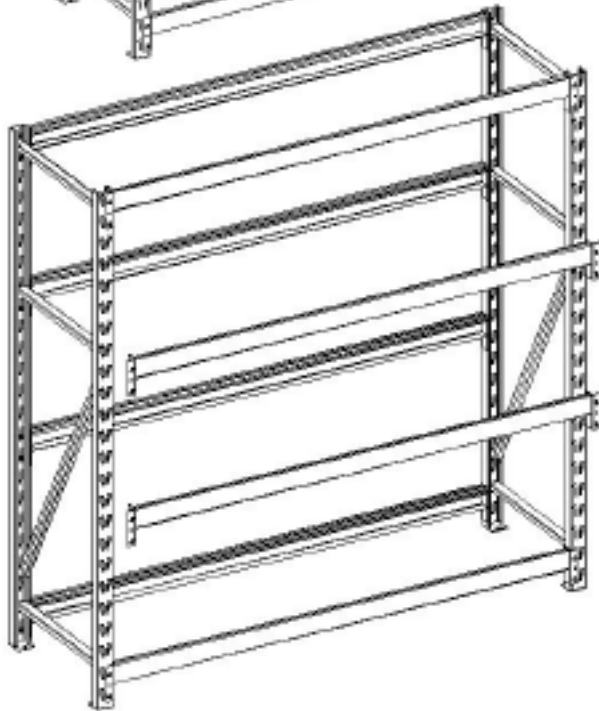

Install a 5th and 6th load beam at desired location.

Be sure the front load beam is at the same level as the back load beam.

Count slots to help you align the load beams height.

Repeat for a 7th and 8th load beam.

## STEP 5:

### WIRE DECK INSTALLATION

Once all load beams are installed, place two wire decks on top inside lip of beams. Refer to side view detail on right.

Repeat for each wire deck.

Refer to detail for each wire deck installation.

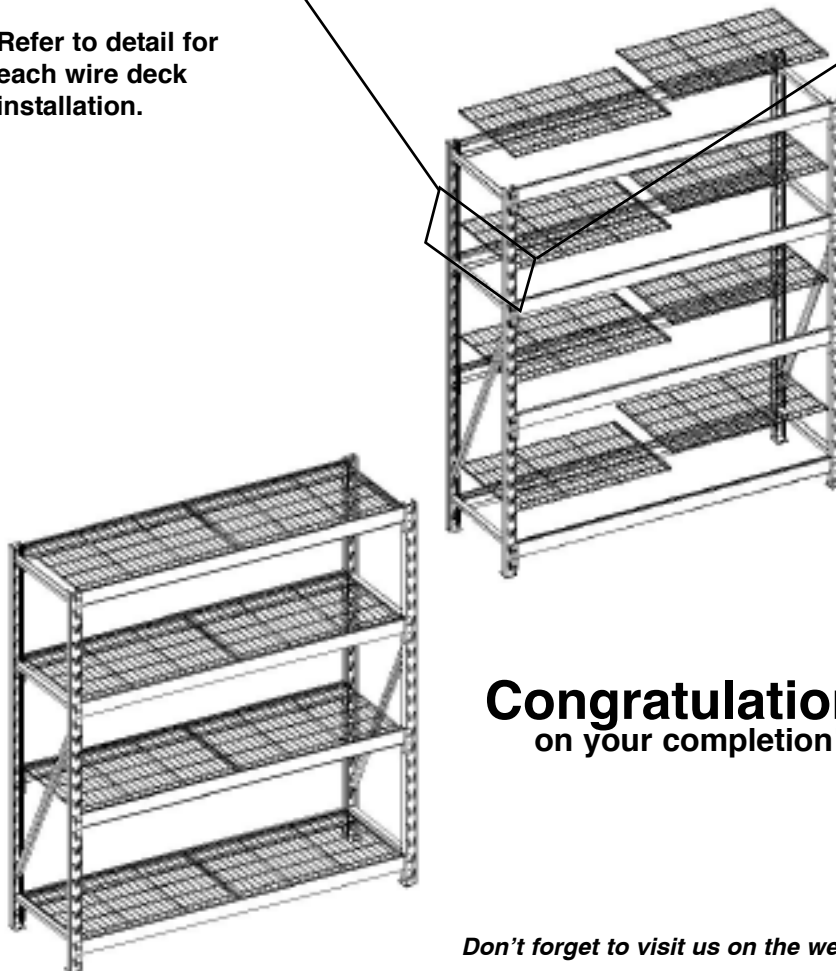
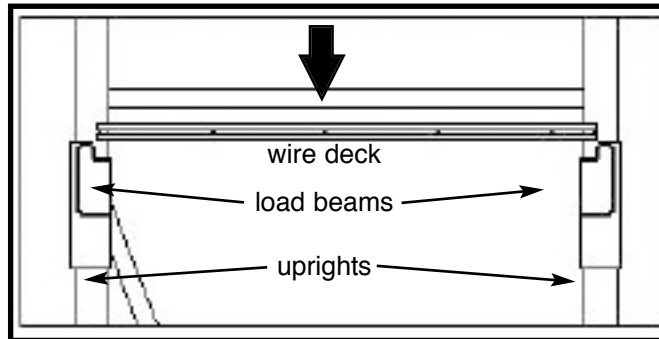

**Congratulations**  
on your completion!

*Don't forget to visit us on the web*

**[www.gorillarak.com](http://www.gorillarak.com)**