

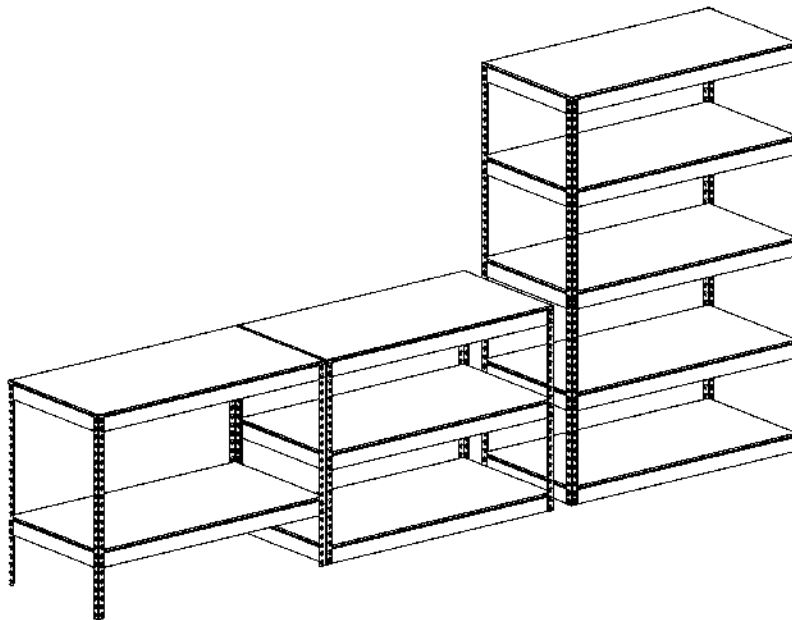

## Assembly Instructions Storage Rack / Workbench



Model: GR 2440-B

Dimensions (DxWxH)  
Storage Rack - 180x860x720  
Workbench - 180x720x860

Model: GR 2560-B

Dimensions (DxWxH)  
Storage Rack - 240x480x720  
Workbench - 240x60x860

*For Instruction Assistance*

 **(800) 637-9508**

*WEEKDAYS: 8:00 a.m. - 5:00 p.m. Pacific Standard Time*

*visit us on the web*

**[www.theshelvingstore.com](http://www.theshelvingstore.com)**

Gorilla Rack Products is a division of  
Rapid Rack Industries, Inc.  
14421 Bonelli Street  
City of Industry, CA 91746

## Congratulations!

You have just purchased a superior quality Gorilla Rack Product!

At Gorilla Rack, we pride ourselves in supplying our customers with a superior quality product. If you require any assistance in assembly, or there are any imperfections in our product we need to know. The call you make as a consumer will make a difference in improved services and innovations. All our products have a limited lifetime warranty.

Please contact us toll free at:  
800-736-7225 (available for US and Canadian customers only)  
Monday through Friday  
8:00 A.M. to 5:00 P.M. Pacific Time.

To better service you, please have available the Model Number and Lot Tracking Number located on the side of the packaging for your customer service representative.

## Warranty

### LIFETIME LIMITED WARRANTY

This Gorilla Rack product (exclusive of shelves) is warranted to the original purchaser against defects in material and workmanship. If there are defects in the product, Rapid Rack will without charge and upon proof of purchase, repair/replace at our discretion. Warranty void if product is subject to misuse, abuse, alteration, improper assembly, accident, if used for other than designated purposes or if maximum load capacities are exceeded. This warranty is not transferable and does not cover chipping, flaking, scratches, rust, dents, or other damages to finish or surface of the product. Responsibility of Rapid Rack Industries is limited to repair or replacement of product. Rapid Rack Industries Inc. is not responsible for consequential, incidental, or other damages or losses resulting from product failure. THIS WARRANTY IS IN LIEU OF ALL OTHER EXPRESS WARRANTIES. SOME STATES DO NOT ALLOW THE EXCLUSION OR LIMITATION OF INCIDENTAL OR CONSEQUENTIAL DAMAGES, SO THE ABOVE LIMITATION MAY NOT APPLY TO YOU. THIS WARRANTY GIVES YOU SPECIFIC LEGAL RIGHTS AND YOU MAY HAVE OTHER RIGHTS THAT VARY FROM STATE TO STATE. In case of product failure, return product to Rapid Rack Industries, Inc., 14421 Bonelli Street, City of Industry, CA 91746.

## Tips

1. Use some type of lubricant to ease the joining of the angle posts and beams.
2. Use a cloth or wood block to protect the surface finish of the product when using a hammer.
3. Rivets must seat at the bottom of the keyhole slot. Hitting the flat section of Double Rivet beam assists.
4. Assemble the unit on a sturdy and level surface. Avoid assembly on carpet.
5. Load small stable items on the top shelves, heavier and bulkier items should be stored on the lower shelves.

### ATTENTION

Storage Rack is not recommended for outdoor use. The particle board decks should be sealed with a water proof sealant or paint when used in humid environment to prevent mold.

Optional Beam Assembly

Flange Down will help keep objects from falling over the edge.

Flange Up will help slide object in or out.

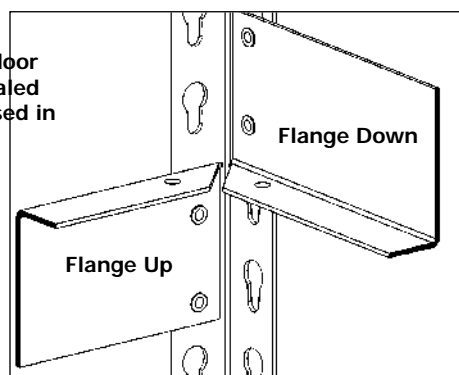

## GR 2440-B OVERVIEW

## WORKBENCH

To facilitate assembly we recommend having two persons assemble the workbench.

Tool required: Rubber Mallet / Hammer

Please read and follow instructions to avoid injuries.

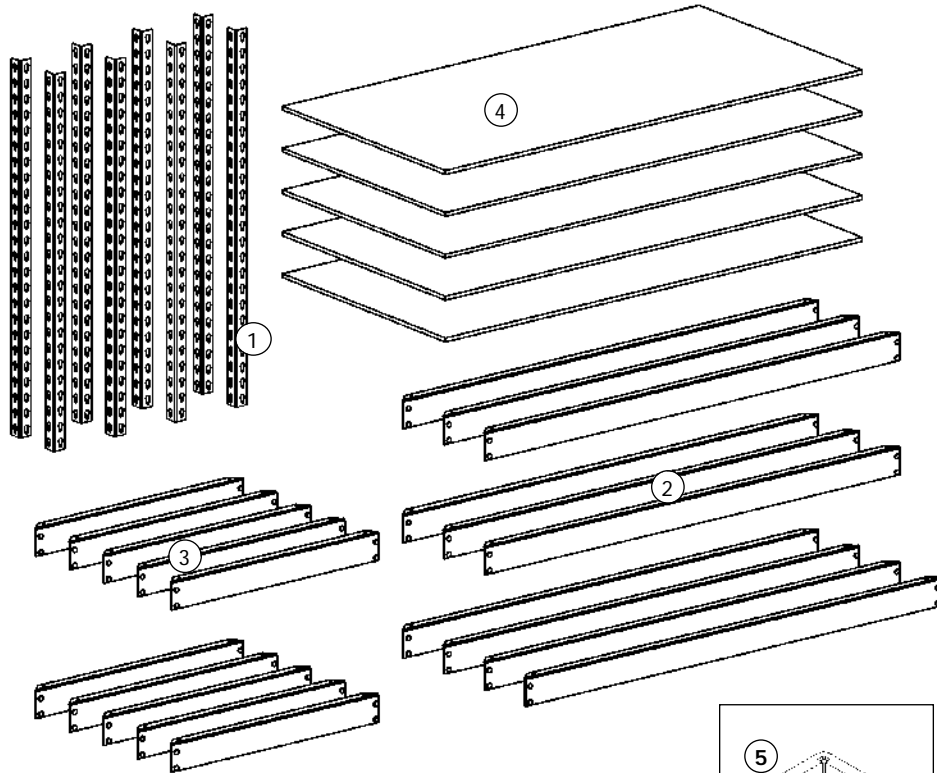

### Contents

Item	Description	Qty.
1	Angle Post 360	8
2	Long Double Rivet Beam	10
3	Short Double Rivet Beam	10
4	Shelf Deck	5
5	Post Caps	8
6	Tie Pins	4

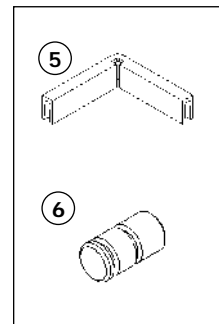

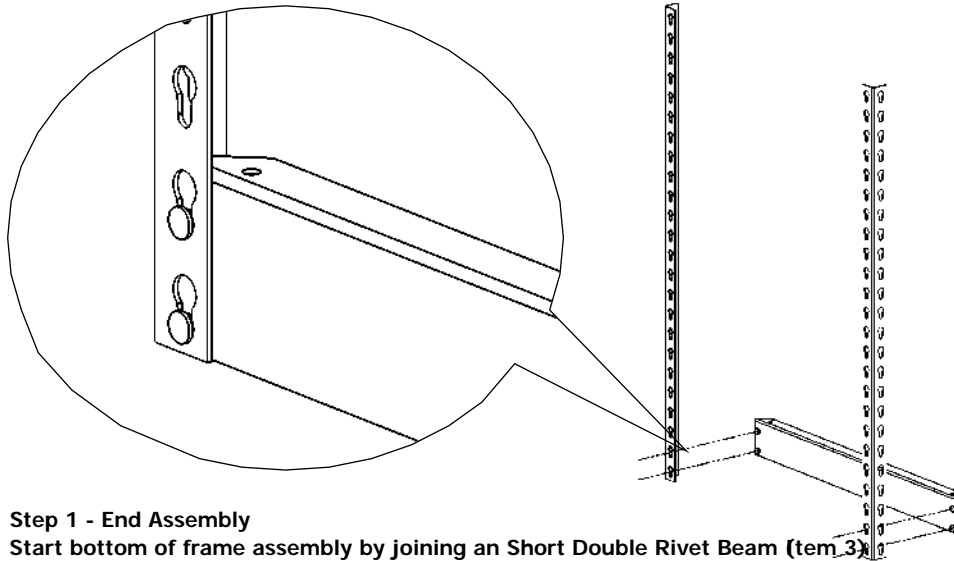

### Step 1 - End Assembly

Start bottom of frame assembly by joining an Short Double Rivet Beam (tem 3) into the two bottom keyholes of a 36"Angle Post (tem 1) Be sure that the flange is up and drive the rivets to the bottom of the key hole by hitting the beam with a rubber mallet.

*Tip: Hit the beam close to joints locking the pieces together.*

Repeat to add the second 36"Angle Post creating a Bottom End.

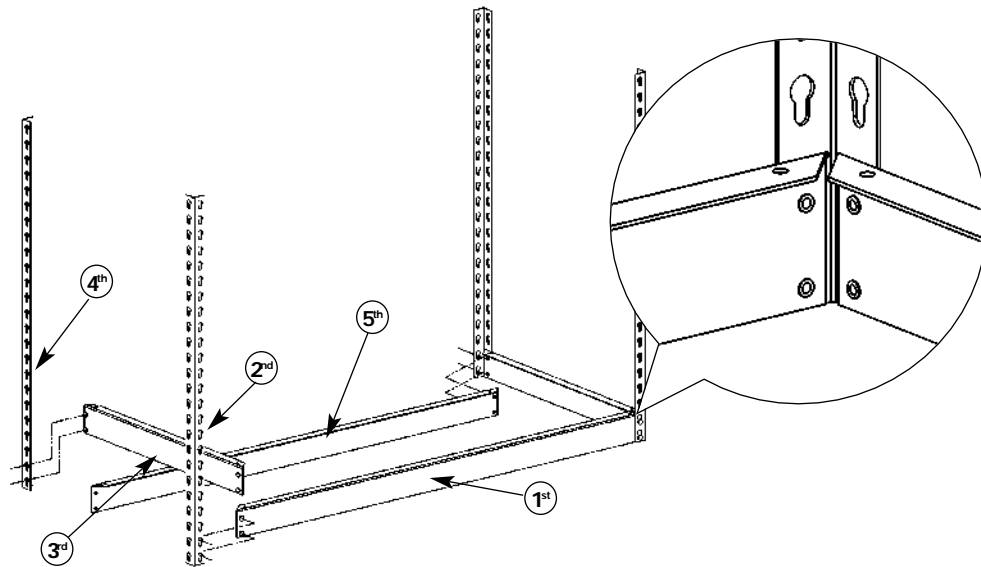

### Step 2 - Primary End and 36" Double Rivet Beams

Assemble a Long Double Rivet Beam (tem 2) to the bottom key holes of the bottom end assembly (refer to detail) Hit the beam with a rubber mallet to lock pieces together. Add the Angle Posts and Short Double Rivet Beam and lock pieces together until complete. All beam flange must be up. Follow the order 1<sup>st</sup> through 5<sup>th</sup> shown in the drawing to facilitate the assembly.

**Note:** Hit the beams near the joints to lock the pieces into place.

**PRIMARY END ASSEMBLY**

**WORK BENCH**

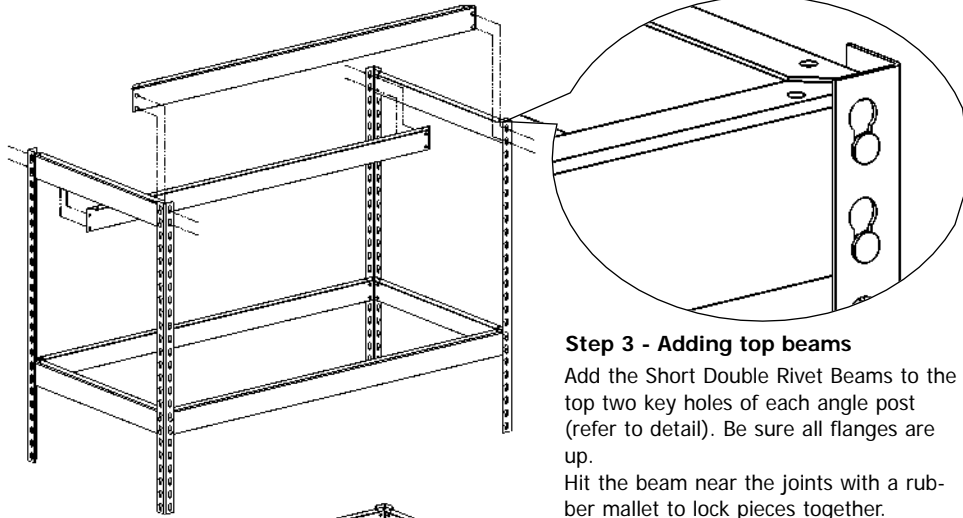

**Step 3 - Adding top beams**

Add the Short Double Rivet Beams to the top two key holes of each angle post (refer to detail). Be sure all flanges are up. Hit the beam near the joints with a rubber mallet to lock pieces together.

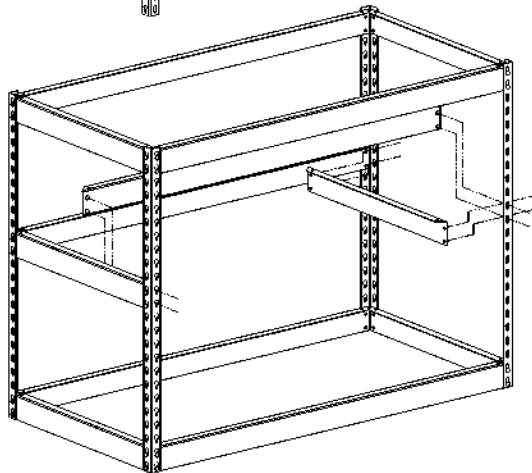

**Step 4 - Adjustable Beams**

Add the two Short Double Rivet Beams with flange up to your desired height, and drive the beams down with a rubber mallet.

**ADD ON UNIT**

**WORKBENCH**

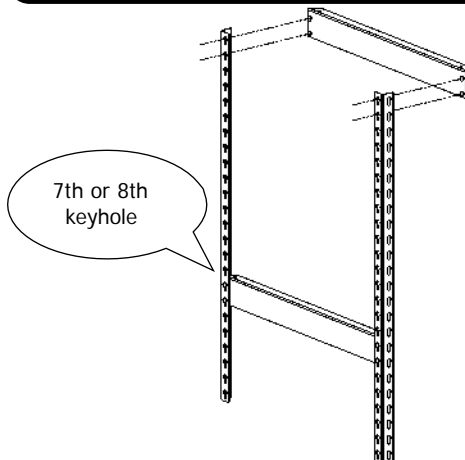

**Step 5 - Add-On Unit End Assembly.**

Start by assembling two 36" Angle Post and two Short Double Rivet Beams. The first Short Double Rivet Beam must be assembled to the top two keyholes of the Angle Post. The second Short Double Rivet Beam must be assembled at the 7<sup>th</sup>-8<sup>th</sup> keyhole from the bottom of the Angle Post.

Repeat for the opposite end.

Hit the beam near the joints with a rubber mallet to lock pieces together.

## ADD ON UNIT

## WORKBENCH

### Step 6 - Completing the Add-On Unit

Assemble the top Long Double Rivet Beams to the top two keyholes of the Angle Post. Assemble the two Long Double Rivet Beams at the 7<sup>th</sup>-8<sup>th</sup> to keyhole. Hit all Beams to lock.

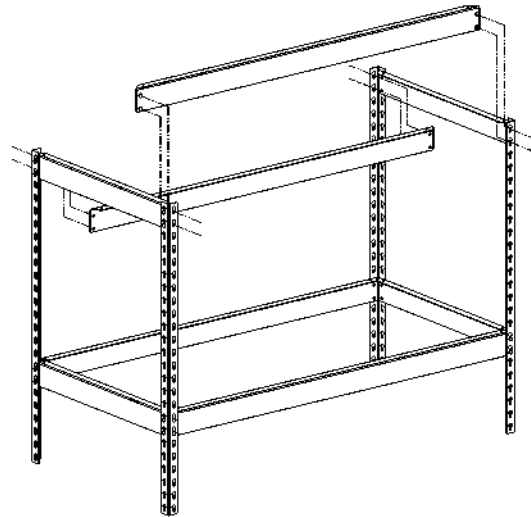

## COMPLETION

## WORKBENCH

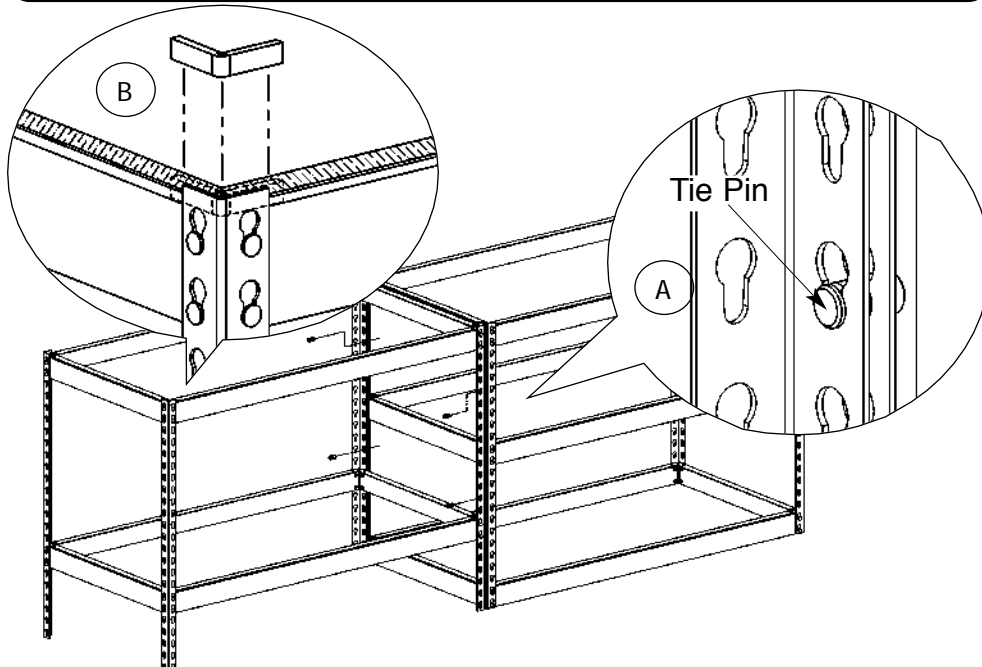

### Step 7 - Tie Pins

Tie Pins (Item 6) may be used to fasten the primary end and add on unit together.

Refer to detail A.

### Step 8 - Completion

Add Post Caps (Item 5) to the top eight exposed Angle Posts. Refer to detail B.

Lay Shelf Decks into place.

Congratulations on your completed work bench!

## PARTS OVERVIEW

## STORAGE RACK

To facilitate assembly we recommend having two persons assemble the storage rack.

Tool required: Rubber Mallet / Hammer

Please read and follow instructions to avoid injuries.

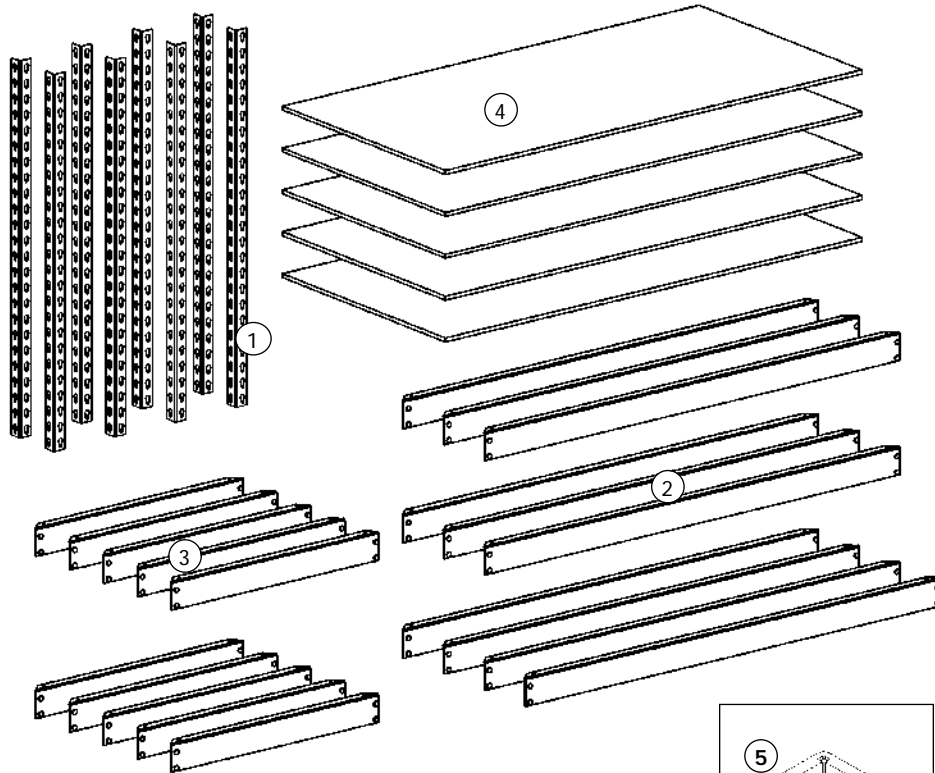

### Contents

Item	Description	Qty.
1	Angle Post 360	8
2	Long Double Rivet Beam	10
3	Short Double Rivet Beam	10
4	Shelf Deck	5
5	Post Caps	8
6	Tie Pins	4

(tie pins maybe used to join more than one storage rack)

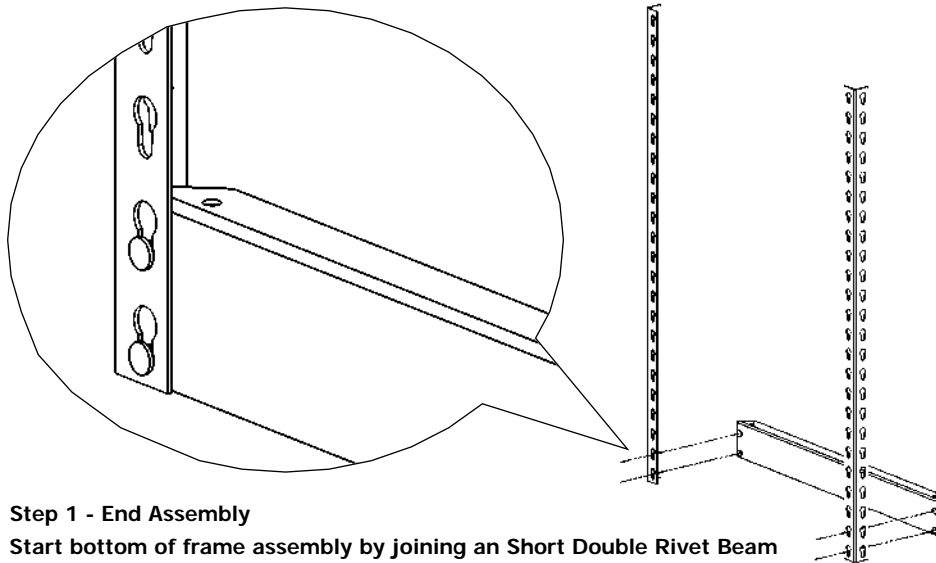

**Step 1 - End Assembly**

Start bottom of frame assembly by joining an Short Double Rivet Beam (tem 3) into the two bottom keyholes of a 36"Angle Post (tem 1) Be sure that the flange is up and drive the rivets to the bottom of the key hole by hitting the beam with a rubber mallet.

*Tip: Hit the beam close to joints locking the pieces together.*

Repeat to add the second 36"Angle Post creating a Bottom End.

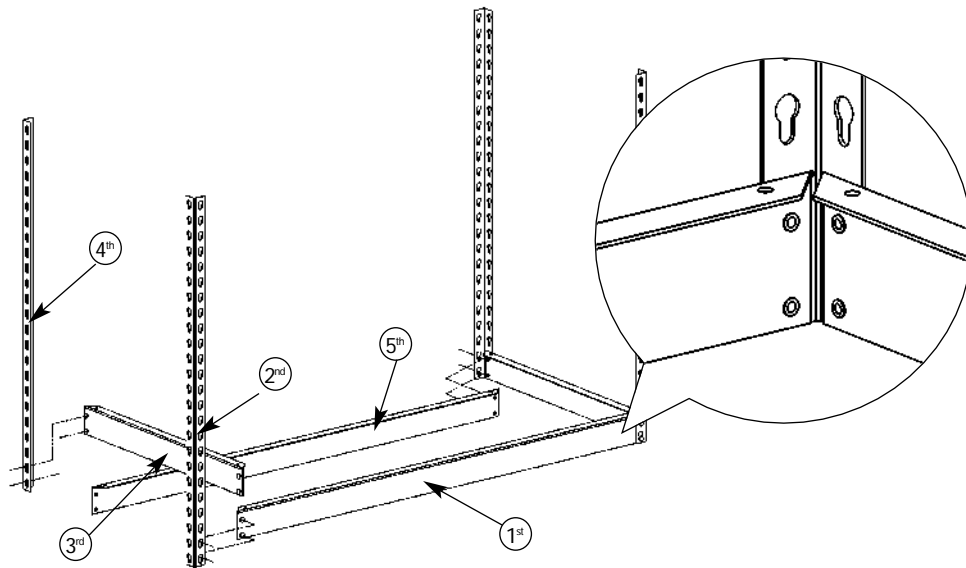

**Step 2 - Primary End and 36"Double Rivet Beams**

Assemble a Long Double Rivet Beam (tem 2) to the bottom key holes of the bottom end assembly (refer to detail) Hit the beam with a rubber mallet to lock pieces together. Add the Angle Posts and Long Double Rivet Beam and lock pieces together until complete. All beam flange must be up. Follow the order 1<sup>st</sup> through 5<sup>th</sup> shown in the drawing to facilitate the assembly.

**Note:** Hit the beams near the joints to lock the pieces into place.



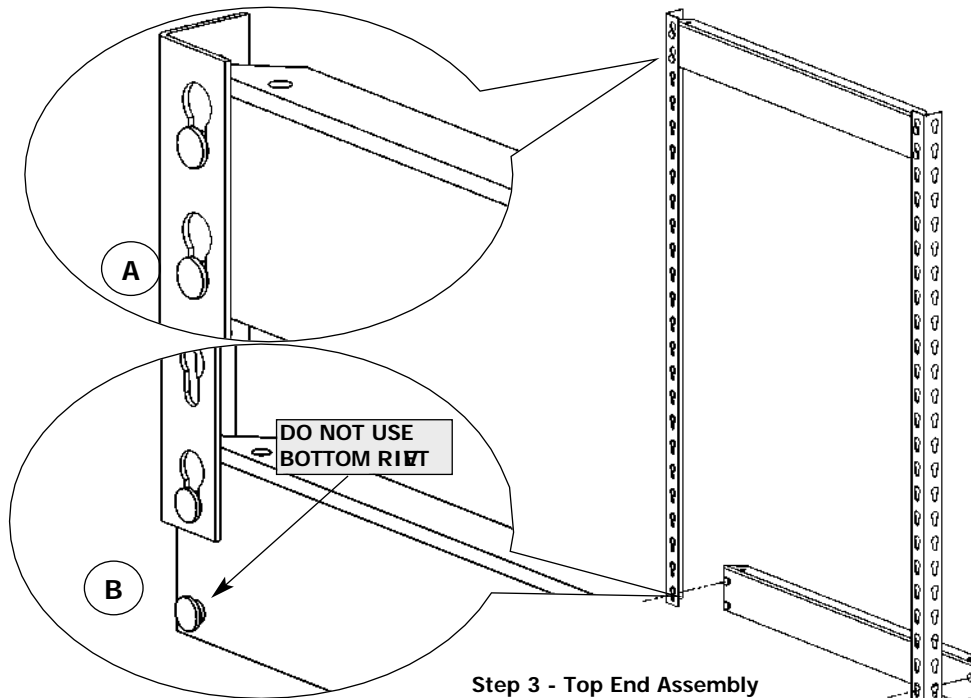

**Step 3 - Top End Assembly**

Start the top end assembly by joining an Short Double Rivet Beam into the top keyholes of a 36" Angle Post (detail A). Add the second 36" Angle Post. Hit the beam close to joints to lock pieces together. Add the Bottom Short Double Rivet Beam (detail B) and lock pieces together. **Only use the top rivet, the bottom rivet will be used to join the top end to the bottom assembly.** Repeat Step for the opposite top end.

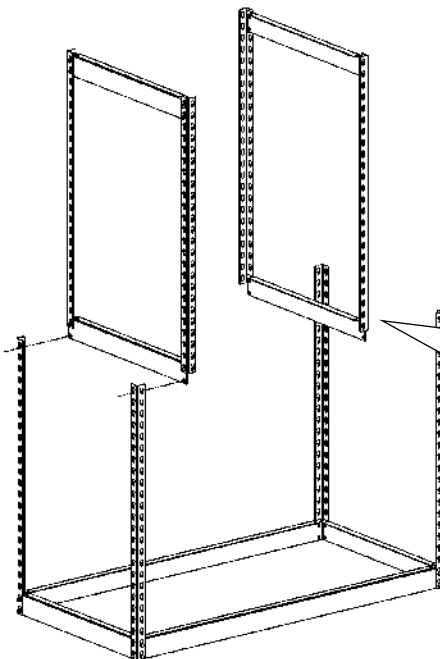

**Step 4 - Joining Assemblies**

Join the top end to the bottom assembly angle post. Insert the open rivets to the top keyhole of the angle post, refer to the detail for proper placement. Insert both rivets into the posts before hitting joints. Repeat Step for the opposite end. Note: Angle posts do not overlap.

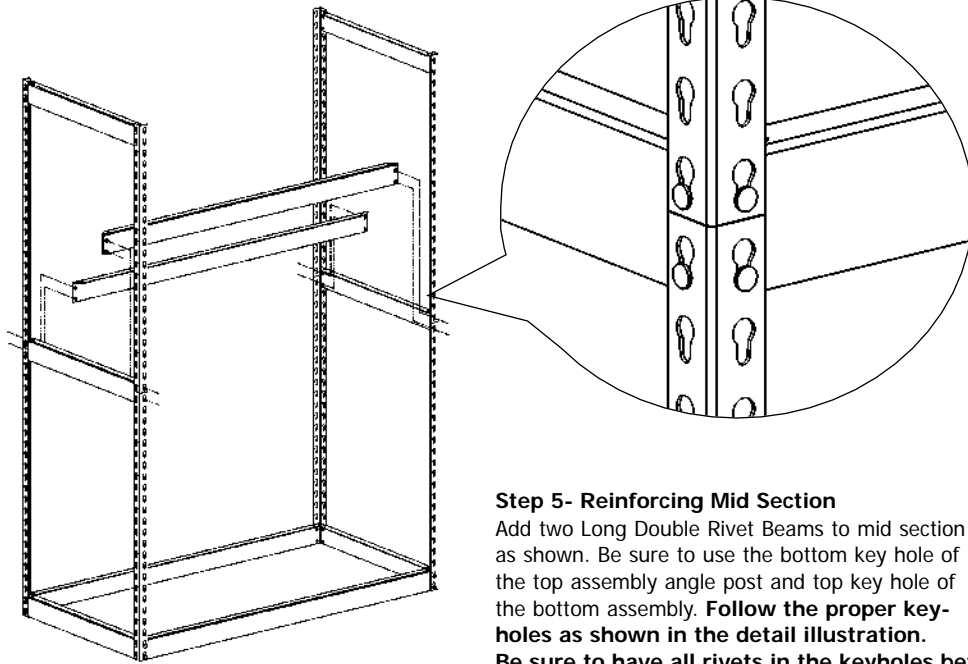
**Step 5- Reinforcing Mid Section**

Add two Long Double Rivet Beams to mid section as shown. Be sure to use the bottom key hole of the top assembly angle post and top key hole of the bottom assembly. **Follow the proper key-holes as shown in the detail illustration.**

**Be sure to have all rivets in the keyholes before hitting the beam.**

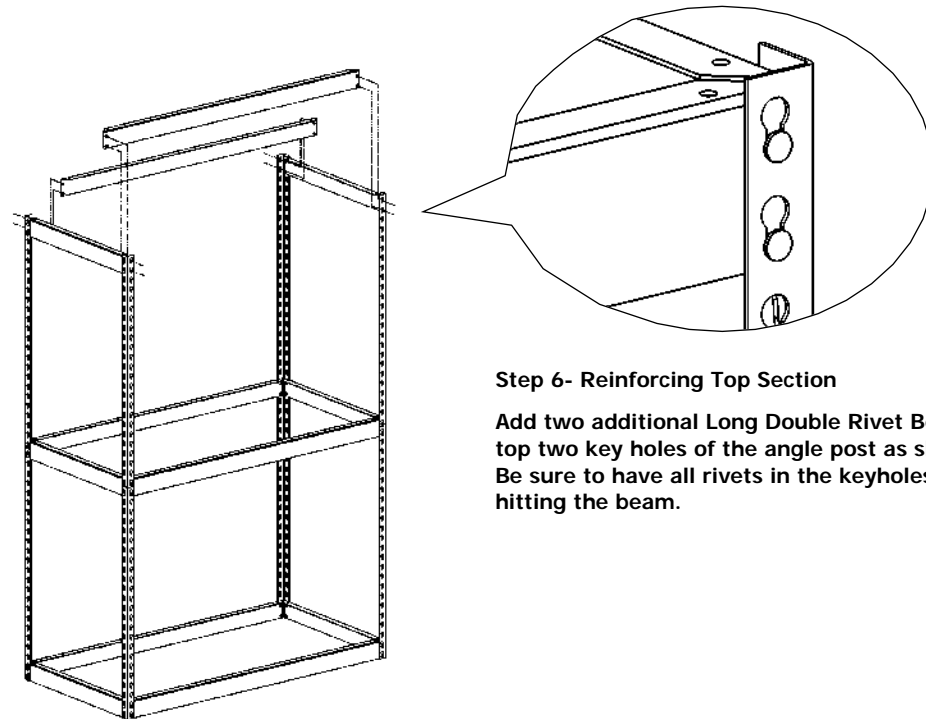
**Step 6- Reinforcing Top Section**

Add two additional Long Double Rivet Beam to top two key holes of the angle post as shown. **Be sure to have all rivets in the keyholes before hitting the beam.**

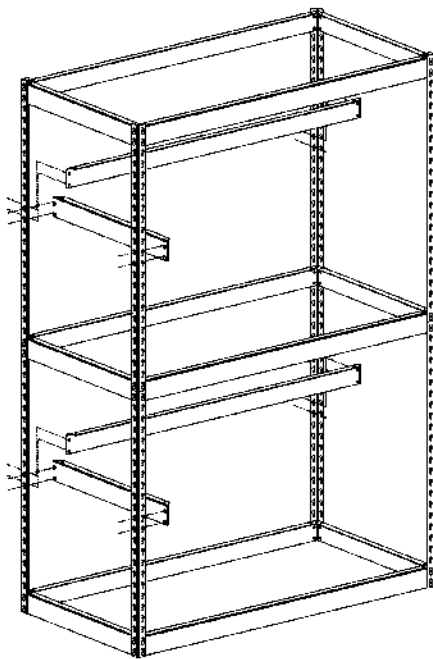
**Step 7 - Shelves**

Assemble the remaining Short and Long Double Rivet Beams to your desired location on the angle post. Hit Beams to lock pieces together.

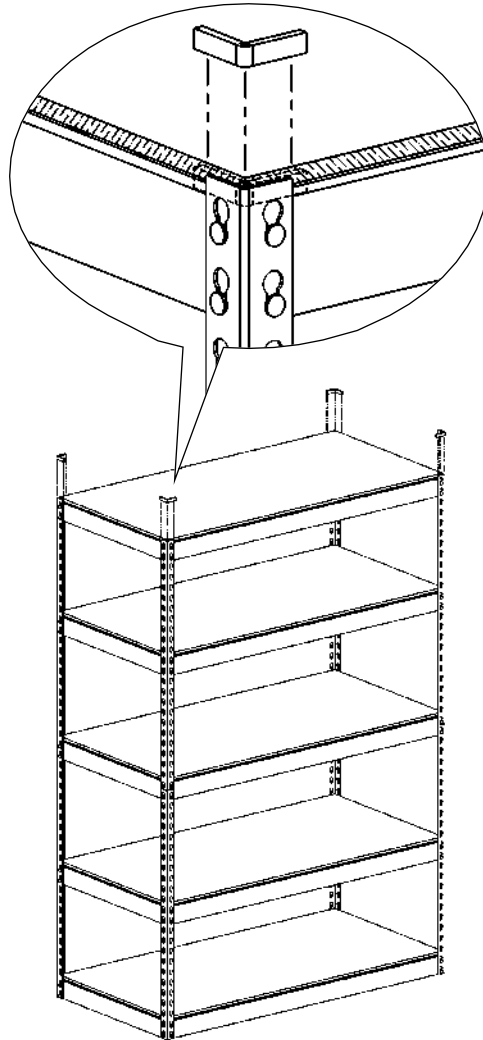
**Step 8 - Post Caps**

Add the Post Caps (Item 5) to the top of the 4 corner Angle Posts as shown in the detail.

Lay the Shelf Decks into Place.

Congratulations on your completed storage rack!